



# FUSION EX

GAMING CHAIR

## ASSEMBLY DRAWING

部件图示, 部件圖示

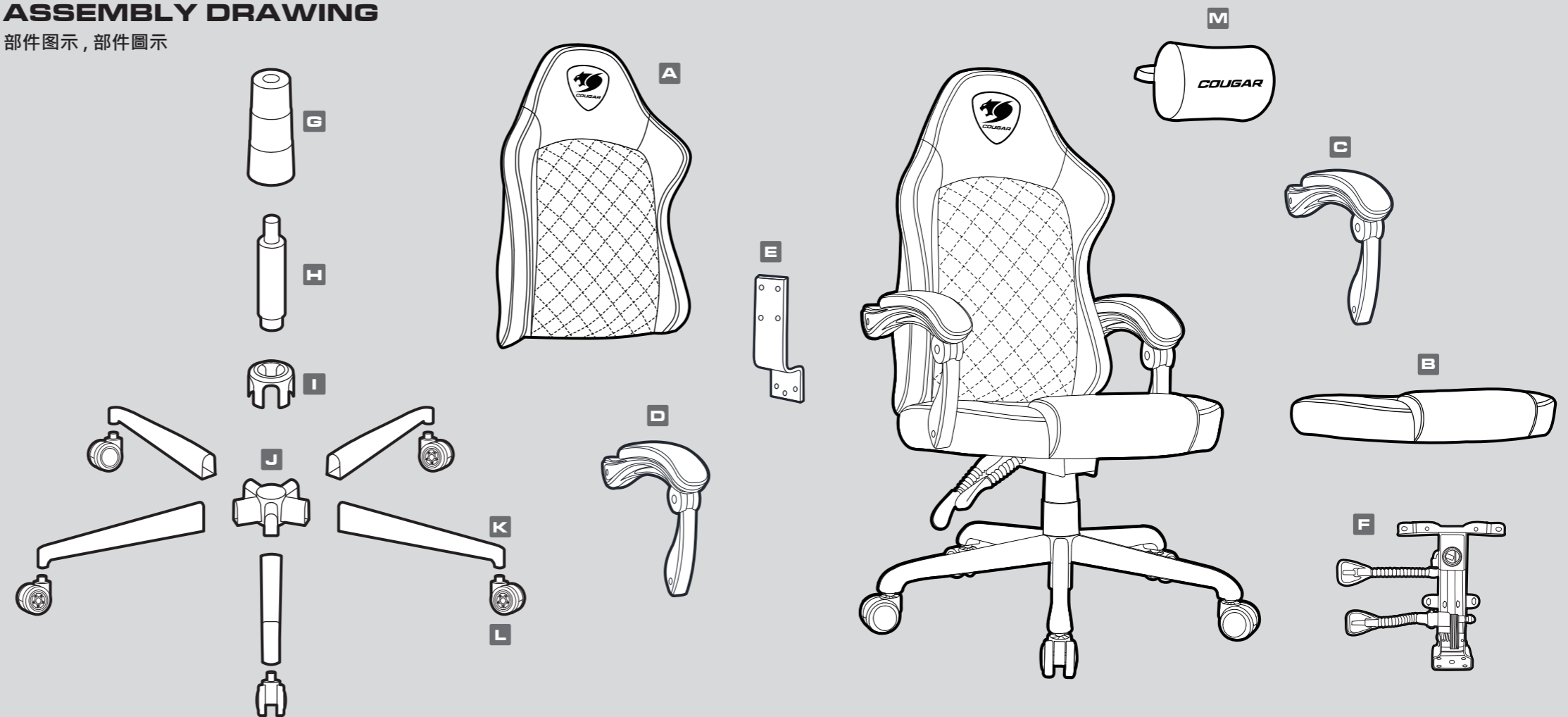

## FEATURES 产品特点, 產品特點

### English

- Leather-like fabric upholstery balances durability with a premium feel.
- Head pillow included for support and comfort.
- Linkage armrests sync with backrest to align arms and shoulders with recline.
- Lumbar support built into backrest provides sofa-grade comfort.
- 5mm mute wheels allow for quiet movement across any surface.

### Русский

- Обивка с эффектом кожи сочетает долговечность и премиальные тактильные ощущения.
- В комплект входит подушка для головы, обеспечивающая поддержку и комфорт.
- Синхронизированные подлокотники движутся вместе со спинкой, выравнивая руки и плечи при отклонении.
- Поясничная поддержка, встроенная в спинку, обеспечивает комфорт уровня дивана.
- Бесшумные колеса диаметром 5 мм позволяют тихо перемещаться по любой поверхности.

### Deutsch

- Der lederähnliche Stoffbezug verbindet Langlebigkeit mit einem hochwertigen Gefühl.
- Inklusive Kopfkissen für zusätzlichen Halt und Komfort.
- Die gekoppelten Armlehnen synchronisieren sich mit der Rückenlehne und halten Arme und Schultern beim Zurücklehnen optimal ausgerichtet.
- Die in die Rückenlehne integrierte Lendenstütze bietet Komfort auf Sofa-Niveau.
- 5-mm-Leichtlaufrollen ermöglichen leises Bewegungen auf jeder Oberfläche.

### 日本語

- レザー調ファブリック張地は、耐久性と高級感を両立。
- サポート性と快適性を高めるヘッドピローを付属。
- 連動式アームレストが背もたれと同期し、リクライニング時も腕と肩を自然に整列。
- 背もたれ内蔵のランバーサポートが、ソファレベルの快適さを提供。
- 5mm静音キャスターにより、あらゆる床面で静かに移動可能。

### 한국어

- 가죽 질감의 패브릭으로 내구성과 프리미엄 감각을 모두 갖췄습니다.
- 지지력과 편안함을 위한 헤드 pillow가 포함되어 있습니다.
- 연동형 팔걸이가 등받이와 함께 움직여 리클라이닝 시 팔과 어깨를 자연스럽게 정렬합니다.
- 등받이에 내장된 허리 지지대가 소파급 편안함을 제공합니다.
- 5mm 저소음 바퀴로 어떤 바닥에서도 조용하게 이동할 수 있습니다.

### Українська мова

- Оббивка з тканини з ефектом шкіри поєднує довговічність і преміальні відчуття.
- У комплекті подушка для голови для підтримки та комфорту.
- Підлокітники з синхронізованим механізмом рухаються разом зі спинкою, вирівнюючи руки та плечі під час нахилу.
- Вбудована в спинку поперекова підтримка забезпечує комфорт рівня дивана.
- Безшумні колеса діаметром 5 мм забезпечують плавний рух на будь-якій поверхні.

### Español

- La tapicería tipo cuero equilibra durabilidad con una sensación premium.
- Incluye almohada para la cabeza que brinda soporte y comodidad.
- Los reposabrazos con sistema de enlace se sincronizan con el respaldo para alinear brazos y hombros al inclinarse.
- El soporte lumbar integrado en el respaldo ofrece comodidad tipo sofá.
- Ruedas silenciosas de 5 mm que permiten un desplazamiento suave sobre cualquier superficie.

### Português

- O revestimento com aparência de couro equilibra durabilidade e toque premium.
- Almofada para a cabeça inclusa, oferecendo suporte e conforto.
- Apoios de braço com sistema de articulação sincronizam com o encosto para alinhar braços e ombros durante o reclínio.
- O suporte lombar integrado ao encosto proporciona conforto de nível sofá.
- Rodízios silenciosos de 5 mm permitem movimentação suave em qualquer superfície.

### Français

- Le revêtement au toucher cuir allie durabilité et sensation haut de gamme.
- Coussin de tête inclus pour un soutien et un confort accru.
- Les accoudoirs à mécanisme synchronisé suivent l'inclinaison du dossier pour aligner bras et épaules.
- Le soutien lombaire intégré au dossier offre un confort digne d'un canapé.
- Roulettes silencieuses de 5 mm pour des déplacements discrets sur toutes les surfaces.

### 簡中

- 仿皮質感布料兼具耐用性與高級觸感
- 隨附頭枕提供舒適且穩定的支撐
- 連動式扶手隨椅背同步調整，使手臂與肩膀在後仰時保持自然對齊
- 內建於椅背的腰部支撐，帶來如沙發般的舒適體驗
- 5mm 靜音輪設計，在各種地面安靜滑移

### 繁中

- 仿皮質感布料兼具耐用性與高級觸感
- 隨附頭枕提供舒適且穩定的支撐
- 連動式扶手隨椅背同步調整，使手臂與肩膀在後仰時保持自然對齊
- 內建於椅背的腰部支撐，帶來如沙發般的舒適體驗
- 5mm 靜音輪設計，在各種地面安靜滑移

## Seat Height Lift

椅座高度調整  
椅座高度調整

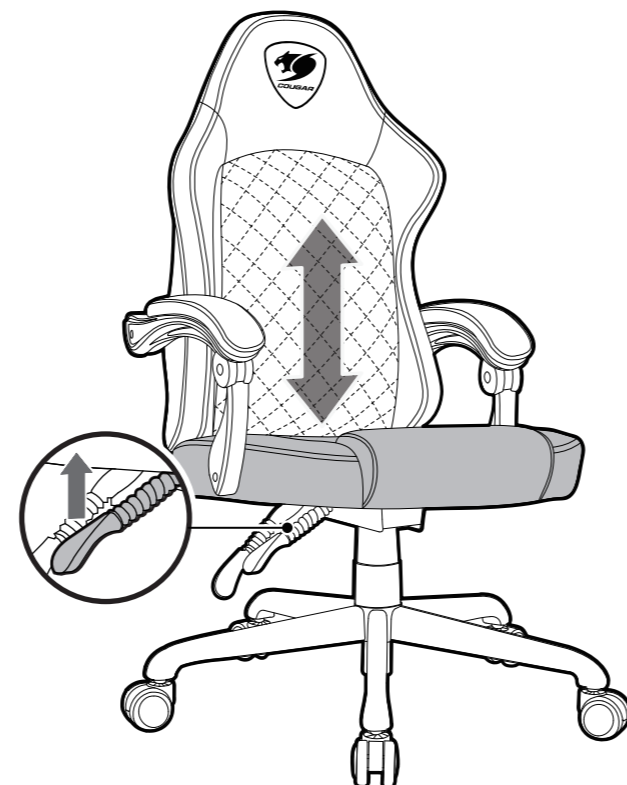

## Angle Adjustor

椅背傾仰調整  
椅背傾仰調整

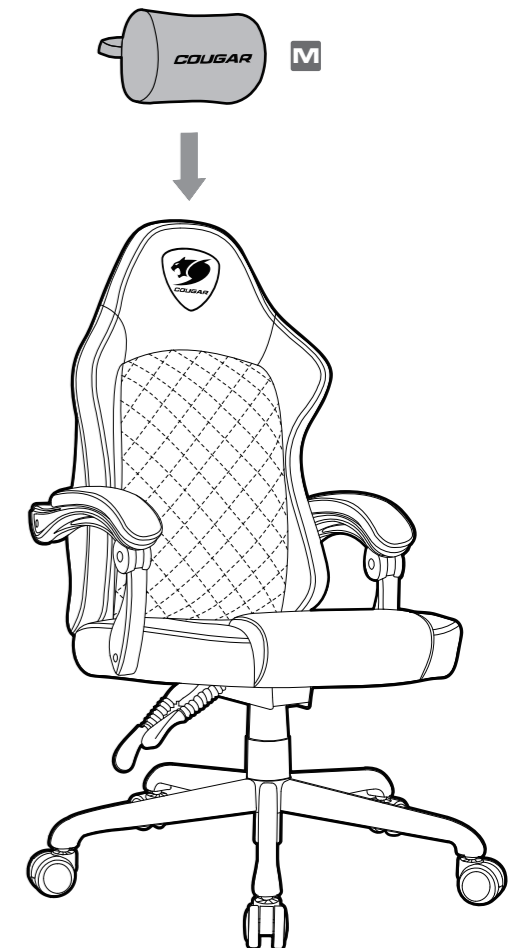

|                            |                           |
|----------------------------|---------------------------|
| <b>1</b><br>M6×25mm<br>x4  | <b>2</b><br>M6×20mm<br>x4 |
| <b>3</b><br>M6×16mm<br>x10 | <b>4</b><br>M8×35mm<br>x4 |
| <b>5</b><br>M8×20mm<br>x3  | <b>6</b><br>x4            |
| <b>7</b><br>5mm<br>x1      |                           |

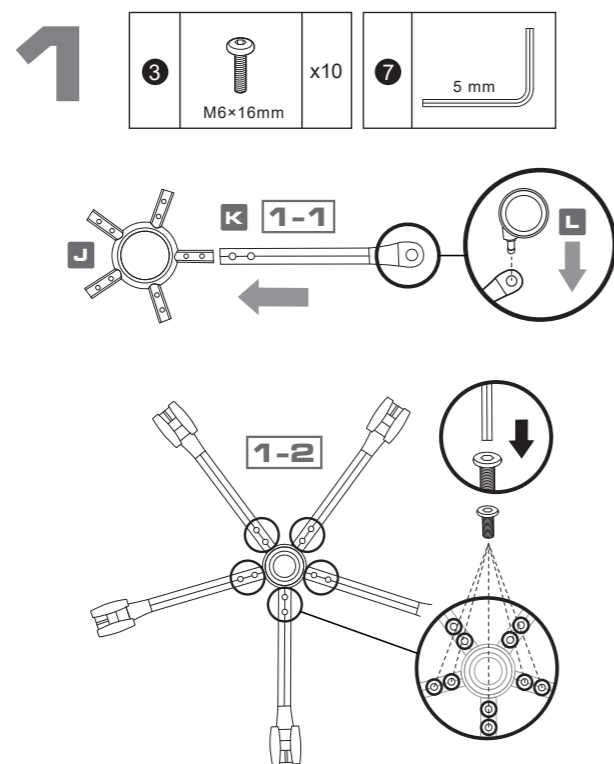

**2**

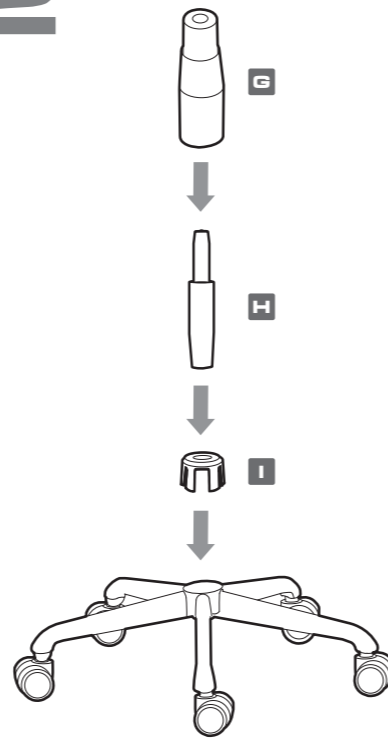

**3**

|                           |                 |
|---------------------------|-----------------|
| <b>2</b><br>M6×20mm<br>x4 | <b>7</b><br>5mm |
|---------------------------|-----------------|

! Screws are pre-installed on the chair.  
螺丝已预装在椅子部件上。  
螺丝已预装在椅子部件上。

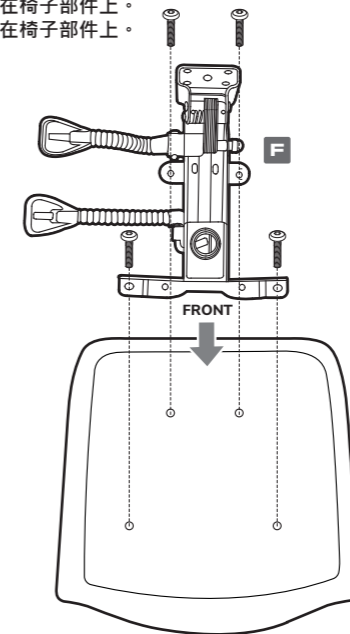

**4**

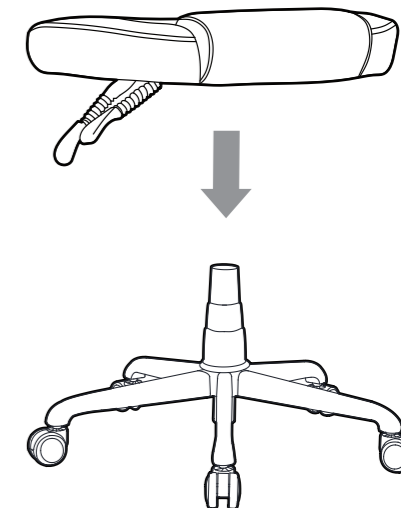

**5**

|                           |                       |
|---------------------------|-----------------------|
| <b>1</b><br>M6×25mm<br>x4 | <b>7</b><br>5mm<br>x1 |
|---------------------------|-----------------------|

**6**

|                           |                       |
|---------------------------|-----------------------|
| <b>5</b><br>M8×20mm<br>x3 | <b>7</b><br>5mm<br>x1 |
|---------------------------|-----------------------|

**7**

|                           |                |                       |
|---------------------------|----------------|-----------------------|
| <b>4</b><br>M8×35mm<br>x4 | <b>6</b><br>x4 | <b>7</b><br>5mm<br>x1 |
|---------------------------|----------------|-----------------------|

! Screws are pre-installed on the chair.  
螺丝已预装在椅子部件上。  
螺丝已预装在椅子部件上。

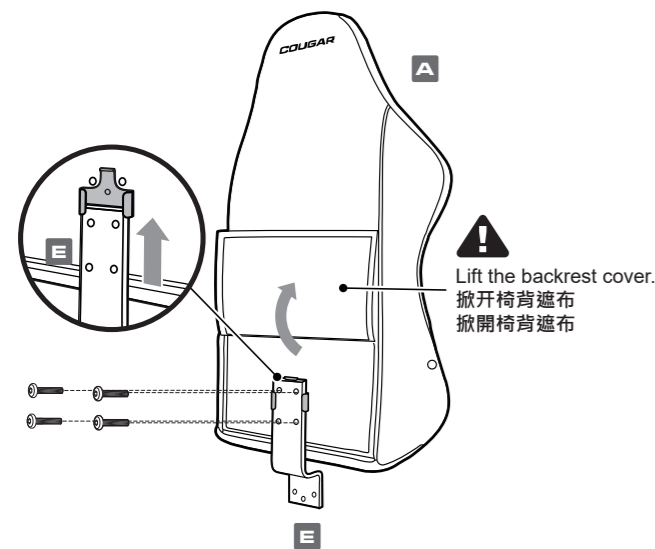

! Lift the backrest cover.  
掀开椅背遮布  
掀开椅背遮布

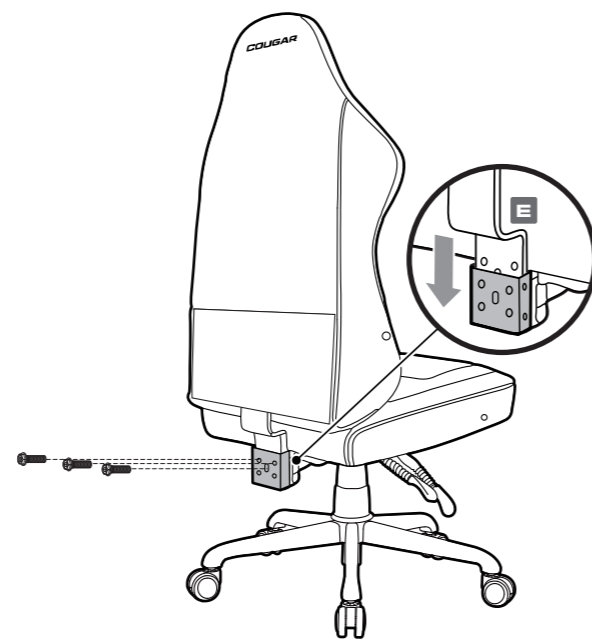

! Pay attention to the assembly sequence for the armrest screws.  
注意扶手螺丝组装顺序。  
注意扶手螺丝组装顺序。



MANUFACTURER CONTACT

制造商联系方式, 製造商聯繫方式

**COUGAR** COUGAR USA Technical Service  
Tel: (833) 256-3778  
www.cougargaming.com Mail: rma@compucaseusa.com

Compucase Enterprise Co., Ltd.  
All rights reserved. Made in China



Official website

Maximum stationary weight capacity 120kg. Please do not place any body or object above 120kg on this chair. From spaces in which it could get caught or be injured.  
本产品最大承受重量120公斤。请勿将120公斤以上的物体放在椅子上。  
本产品最大承受重量120公斤。請勿將120公斤以上的物體放在椅子上。

DISTRIBUTOR



GLOBAL WARRANTY POLICY

全球保固条款, 全球保固條款

WARRANTY PERIODS OF COUGAR GAMING DEVICES

Product : COUGAR FUSION EX Gaming Chair  
Warranty : Please refer to our official website.  
(https://cougargaming.com/us/support/warranty/)  
保固政策: 中国地区购买, 请参考中国地区官方网站。  
(http://cougargaming.com.cn/support/warranty/)



詳細保固條件  
請掃描QR Code

This warranty gives you specific legal rights. You may also have other rights granted under local law. These rights may vary.

WARRANTY AGREEMENT

If the product has defects in material or manufacture, COUGAR will provide product repair and replacement service within the warranty period.  
Our warranty service is based on the date of the invoice or warranty card.

CONDITIONS WHERE FREE MAINTENANCE IS NOT PROVIDED

- Any fault or damage caused by natural disasters (including storm, fire, flood, thunder, earthquake, etc).
- Any fault or damage caused by accidental factors and man-made reasons (including hit, scrape, crash, moving, compression, stain, corrosion, riot, misuse, malicious damage, etc).
- Use in an improper operating environment (including high temperature, high humidity, water inflow, etc).
- Inability to provide the product warranty card, purchase receipt or invoice to prove the product is still within the warranty period and the shipping date of the product is out of warranty.
- The warranty card has been altered or its number is hard to identify.
- The warranty period has expired.

- Any fault or damage caused by non-compliance with regulations stated on the user manual or improper, rough and careless treatment.
- COUGAR is not liable for any damage of life and limb or damage or loss of property caused by or during COUGAR products' use as or with medical equipment, military equipment, traffic equipment and disaster prevention systems.
- COUGAR's warranty liability is limited to repair or replacement. The decision on whether to repair or replace belongs exclusively to COUGAR.
- COUGAR is, to the extent not prohibited by law, not liable for any damages; expenses; lost data, revenues, savings or profits; or any incidental or consequential damages happened while the use of a defective product from COUGAR or due to its use.

DISCLAIMERS

COUGAR products should not be used as critical components in life support devices.  
COUGAR is not liable for any damage of life and limb or damage or loss of property caused by or during COUGAR products' use as or with medical equipment, military equipment, traffic equipment and disaster prevention systems.  
COUGAR's warranty liability is limited to repair or replacement. The decision on whether to repair or replace belongs exclusively to COUGAR.

LEGAL NOTICES

This manual was created by Compucase Enterprise and may not be completely or partially copied, passed on, distributed or stored without written consent by Compucase Enterprise.  
COUGAR® is a registered brand of Compucase Enterprise. Other product and company names mentioned in this documentation may be brands or trademarks of their respective owners.  
Compucase Enterprise reserves the right to make changes concerning the contents of the manual and the technical data of the product without previous announcement.

WARNING

- To adjust the chair height, gently pull the lever up. Do not use excessive force to pull the lever.
- Please wear protective gloves when assembling the chair. It is your own responsibility to use appropriate protection to prevent any physical damage.
- When rocking the chair, using it in any other way or adjusting the height, inclination, position or balance of the chair or any of its components, please pay attention to your hand's position and keep it away from spaces in which it could get caught or be injured.
- Do not make fast or violent movements when the chair is in movement.
- Do not touch any of the chair's adjustment controls to prevent affecting its stability and causing a potentially dangerous fall.
- When reclining the chair to its full extent, set the related control level in lock position and keep both feet on the ground, as well as abstain from any violent, rough or strong movement which could cause the chair to tip over.
- Keep in mind that this chair is designed only for sitting and reclining, and that it should be used only for those uses.
- Do not sit on the edge of the chair or the arm rests.
- Do not place the chair in a location in which it is likely to be subjected to prolonged sunlight exposure.
- The product's colors might fade when exposed to sunlight.
- Do not use abrasive products or scrub energetically when cleaning. Please stick to gentle products suitable for delicate materials.
- All parts should be checked monthly to confirm their integrity and to make sure that the screws are not loose.
- If any part of the product is or appears to be damaged, missing or loose, please contact the local distributor and do not use the product.

Дата изготовления продукции (существует 2 способа определения даты изготовления, оба способа описаны ниже)

После S/N: первые две цифры означают год, вторые две – месяц изготовления. Например, S/N: H170200001 означает, что товар был произведен в феврале 2017 года.

После S/N: если указаны буквы, то две буквы представляют цифры из таблицы ниже, и означают год, следующие две цифры – месяц изготовления. Например, S/N: DAG02REVI000001 означает, что товар был произведен в феврале 2017 года.

|   |   |   |   |   |   |   |   |   |   |
|---|---|---|---|---|---|---|---|---|---|
| A | B | C | D | E | F | G | H | I | J |
| 1 | 2 | 3 | 4 | 5 | 6 | 7 | 8 | 9 | 0 |

• Например, AG = 17 = 2017 год



Pensez à donner ou recycler. Association Magasin Déchèterie  
https://quefairemedesdechets.fr